

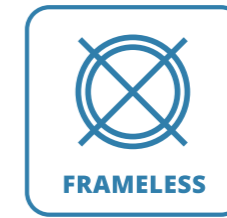

LINE



LINE model diffusers are an elegant and flexible interior design solution. Using this model, it's possible to create strikingly unique interior elements or, in contrast, make the diffuser almost invisible.

By selecting the right model size, it becomes easy to create interesting ceiling designs. Alternatively, it is also possible to create an illusion of no diffuser at all. That is achieved by opting for the SLIM model. In the event of form over function, our LINE diffusers can also be used as imitations, to create an endless line without breaks. This way, unique interior design solutions can be made real.

LINE diffuser models are more than just interior design elements, but a practical solution. They are the first diffusers on the market that can be painted with the same paint as the rest of the surface and leave no frames to look at. In addition, even standard LINE models can be adapted to your needs:

·1-slot, 2-slot or 3-slot types are available from LINE models.

·625mm; 1000mm; 1250mm - you can choose these standard lengths of the LINE diffuser models.

·12mm or 18mm – you can choose these standard slot widths of the LINE diffuser models.

Even standard diffuser models can be flexibly adapted to your needs. They can be connected in an infinite line with unobtrusive connections. These unique solutions do not require lowering of the ceiling height.

You can place all standard size orders in the order form below.

If your project requires non-standard solutions, or your market requires specific dimensions of LINE diffusers - we can help you.

Fill out the order form below and select a bespoke order. Our consultants will contact you and together we will discuss the fulfilment of your order.

We also invite you to get acquainted in detail with the technical information of LINE model diffuser, which you can do by reading through our catalogue.

Finally, to witness how easy it is to install LINE diffusers, we invite you to watch our product showcase video.

Ventmann – your choice of air elegance.



Installation:
video instructions
 YouTube



Download a digital
version of the catalog
 Download

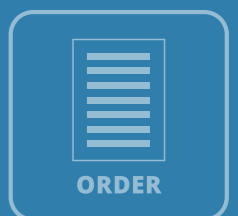
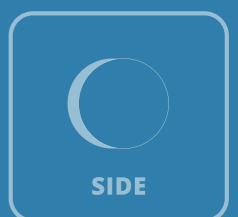
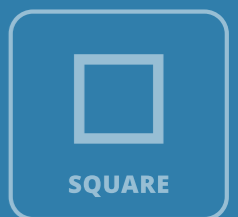
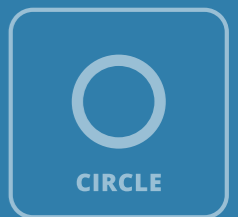

LINE 1/12

SLOT DIFFUSER

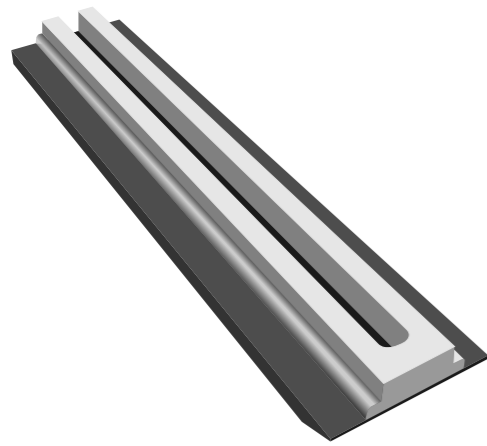

1
AMOUNT OF SLOTS

12 mm
WIDTH OF SLOT

2.5 kg
1 M. LENGTH DIFFUSER WEIGHT
WITHOUT PACKAGING (NET)

625 / 1000 / 1250
STANDARD SLOT LENGTH (MM)

Steel punched sheet. Distributes the air supply through the diffuser.

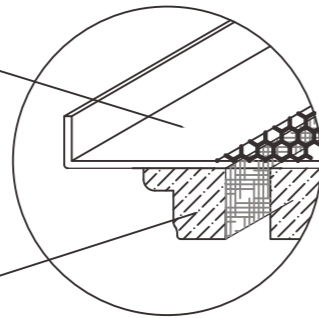

Gypsum mix segment. Sanded, puttied, painted. Suitable for all operations in combination with surface finishing

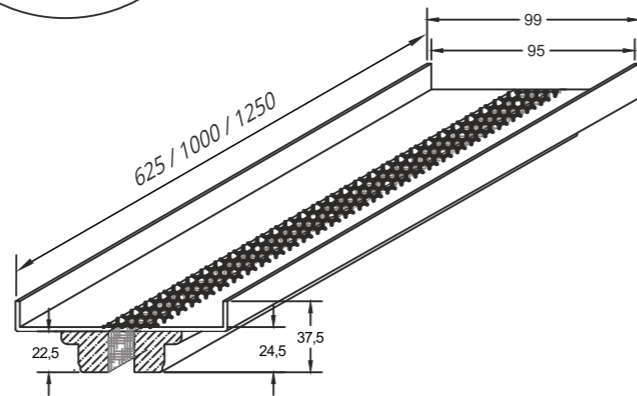
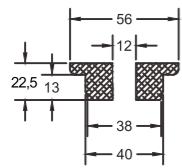

Slot narrower by a third, which is less noticeable indoors, is called the Slim version. When the gap is narrowed, the diffuser hardly loses its technical capabilities. Great choice for subtle integration of diffuser into minimalist spaces.

PERCEPTIBLE AIRSPEED $L_{0,2}(m)$ DISTANCE

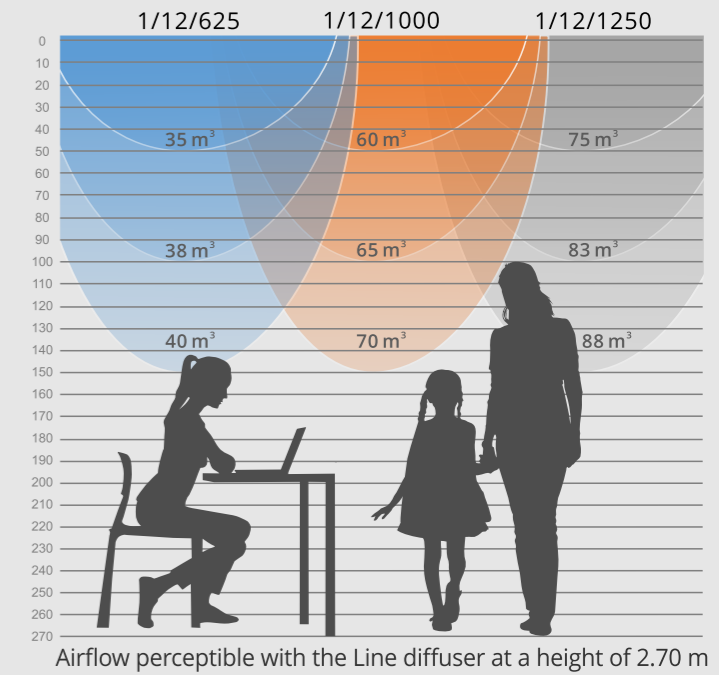

PERCEPTIBLE AIRSPEED REACH LIMIT

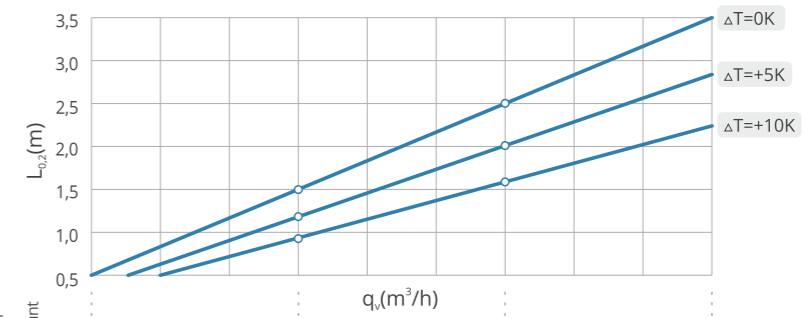

Order code:	slot length	slot amount	slot width
LINE 625 1 12	35	40	45
LINE 1000 1 12	60	70	80
LINE 1250 1 12	75	88	102
LINE 625 1 18	35	40	45
LINE 1000 1 18	60	77	94
LINE 1250 1 18	75	97	118

Airborne noise and resistance, 1 m.

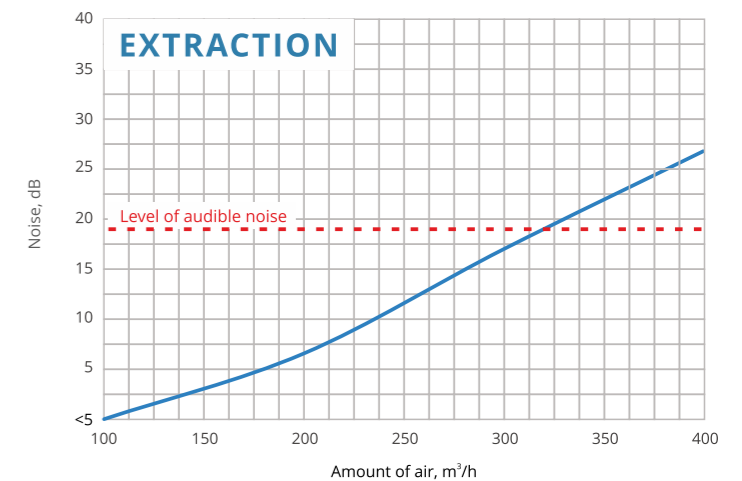
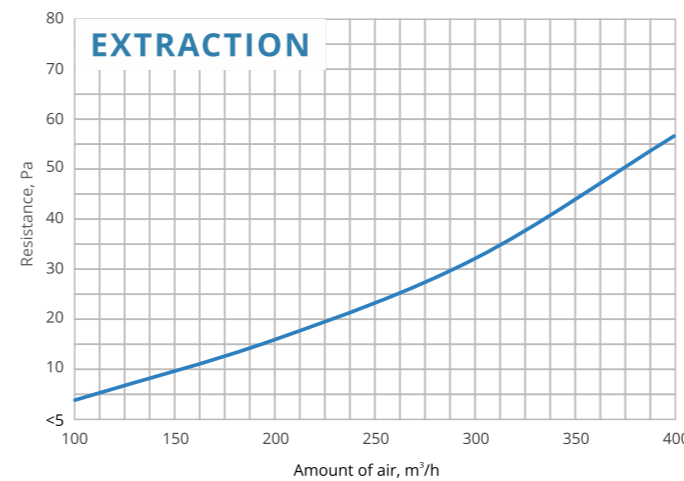
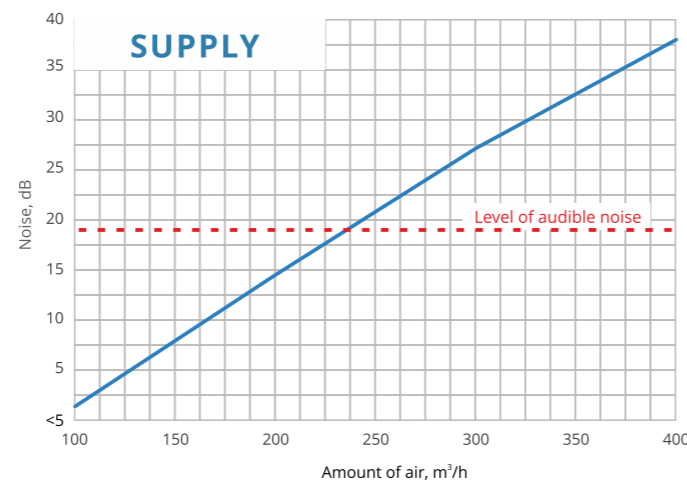
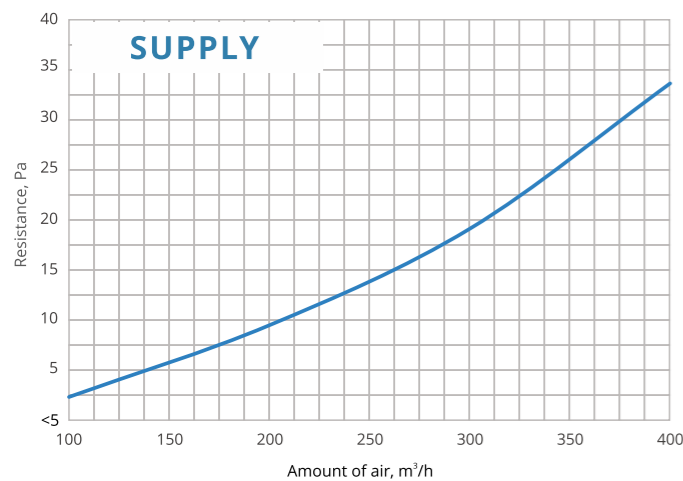

LINE 1/18

SLOT DIFFUSER

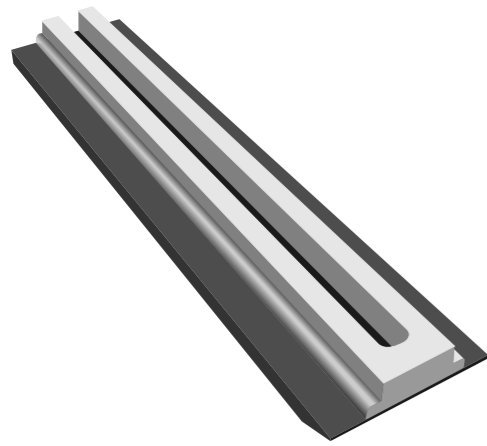

1
AMOUNT OF SLOTS

18 mm
WIDTH OF SLOT

2.5 kg
1 M. LENGTH DIFFUSER WEIGHT
WITHOUT PACKAGING (NET)

625 / 1000 / 1250
STANDARD SLOT LENGTH (MM)

Steel punched sheet. Distributes the air supply through the diffuser.

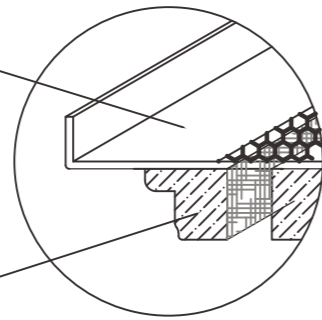

Gypsum mix segment. Sanded, puttied, painted. Suitable for all operations in combination with surface finishing

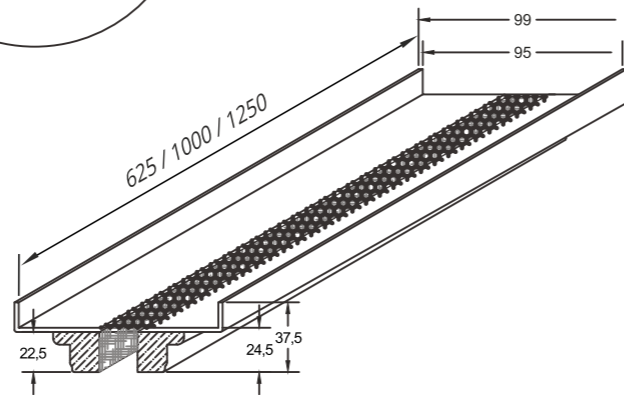
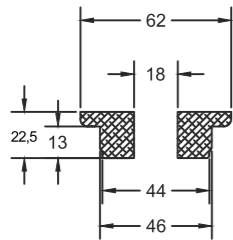

One slot diffuser gives the interior a feeling of lightness, seamlessly integrates the ventilation system into the space, adds elegance and exclusivity.

PERCEPTIBLE AIRSPEED $L_{0,2}(m)$ DISTANCE

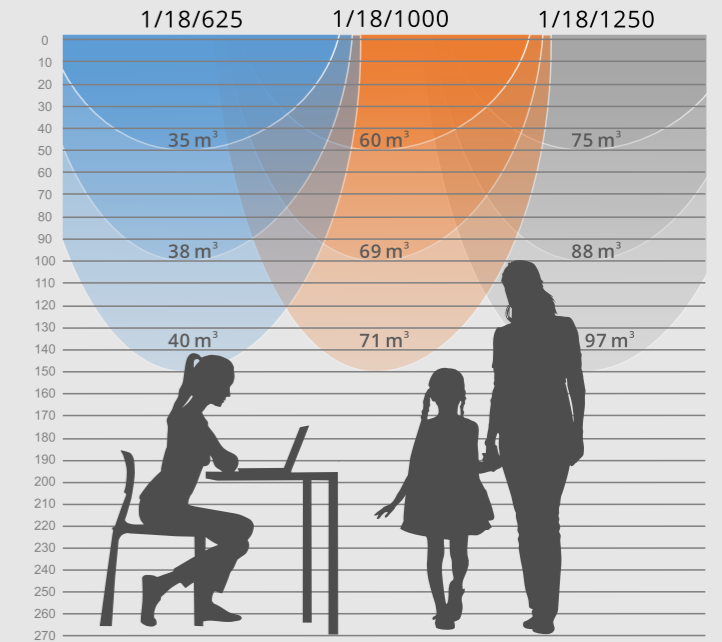

Airflow perceptible with the Line diffuser at a height of 2.70 m

PERCEPTIBLE AIRSPEED REACH LIMIT

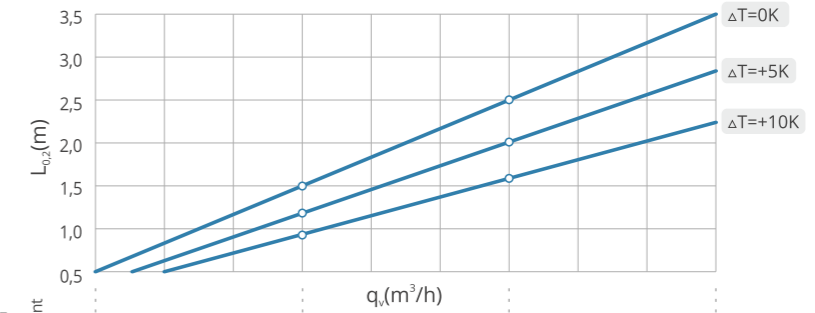

Order code:

Order code	Line length	Line amount	Line width	35	40	45	50
LINE 625 1 12	625	1	12	35	40	45	50
LINE 1000 1 12	1000	1	12	60	70	80	90
LINE 1250 1 12	1250	1	12	75	88	102	115
LINE 625 1 18	625	1	18	35	40	45	70
LINE 1000 1 18	1000	1	18	60	77	94	110
LINE 1250 1 18	1250	1	18	75	97	118	140

Airborne noise and resistance, 1 m.

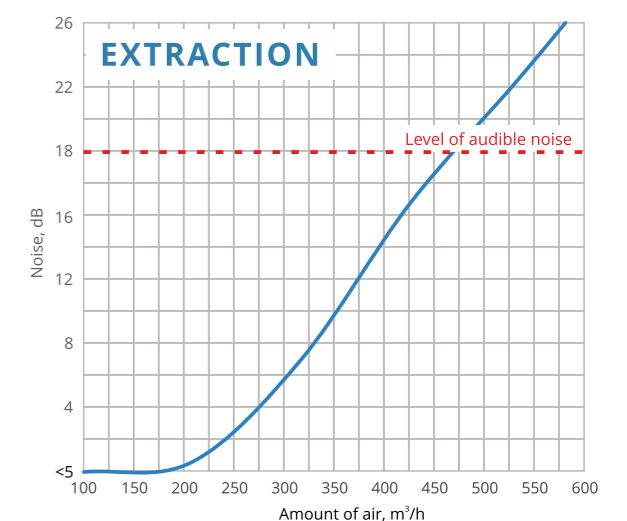
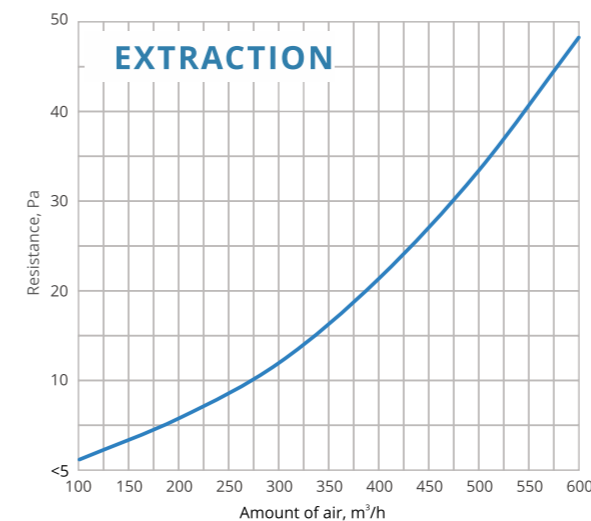
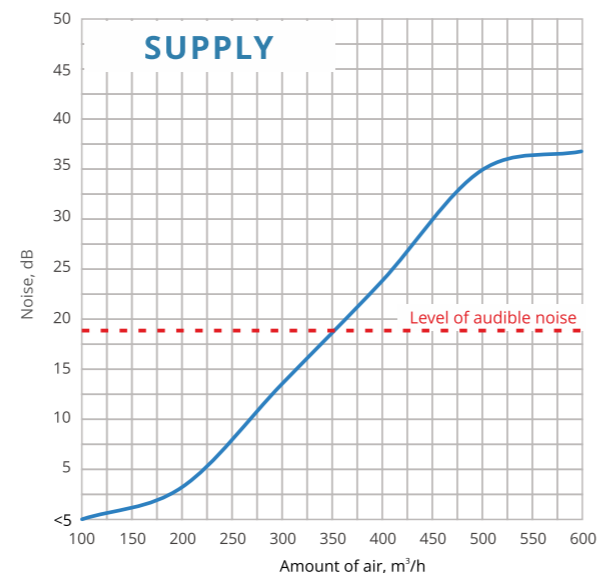
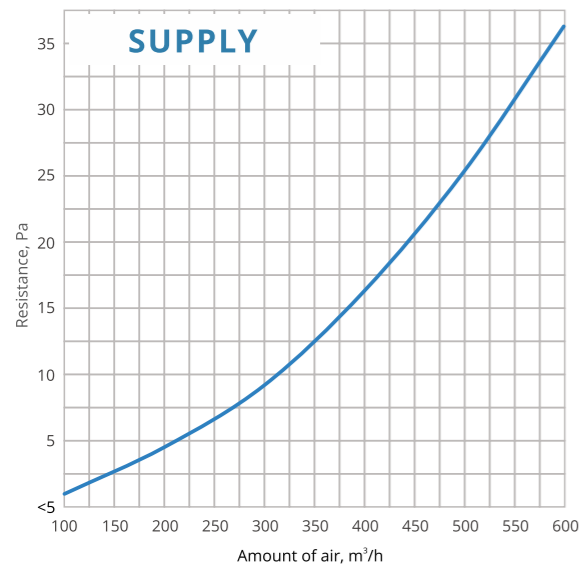

LINE 2/12

SLOT DIFFUSER

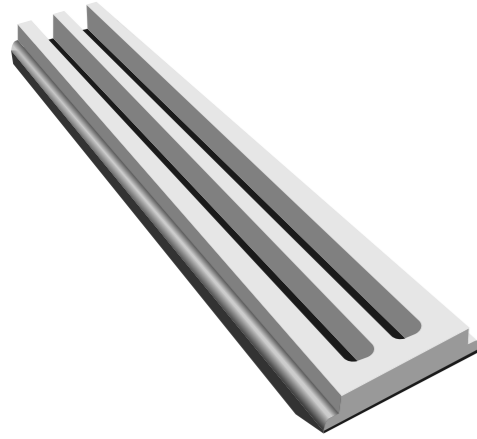

2
AMOUNT OF SLOTS

12 mm
WIDTH OF SLOT

2.735 kg
1 M. LENGTH DIFFUSER WEIGHT
WITHOUT PACKAGING (NET)

625 / 1000 / 1250
STANDARD SLOT LENGTH (MM)

Steel punched sheet. Distributes the air supply through the diffuser.

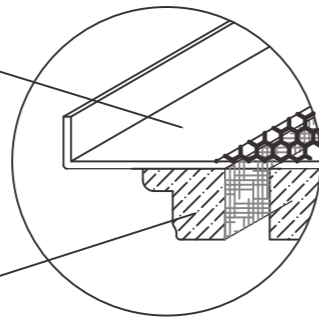

Gypsum mix segment. Sanded, puttied, painted. Suitable for all operations in combination with surface finishing

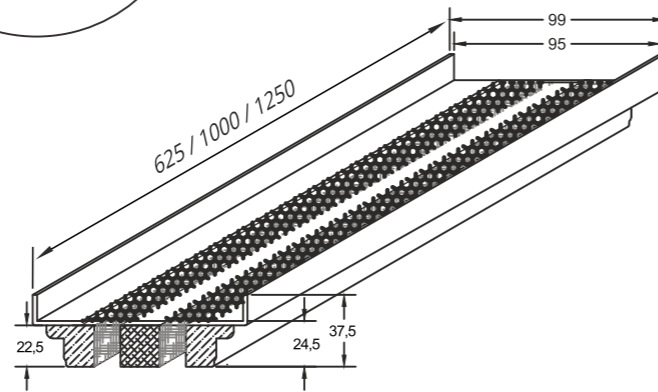
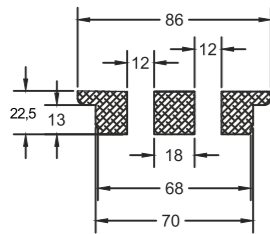

Slim slots are narrower by 30%, making them harder to spot in the environment. However, they do not compromise too much on functionality and aerodynamic properties. They are easily integrated into both walls and ceilings.

PERCEPTIBLE AIRSPEED $L_{0,2}(m)$ DISTANCE

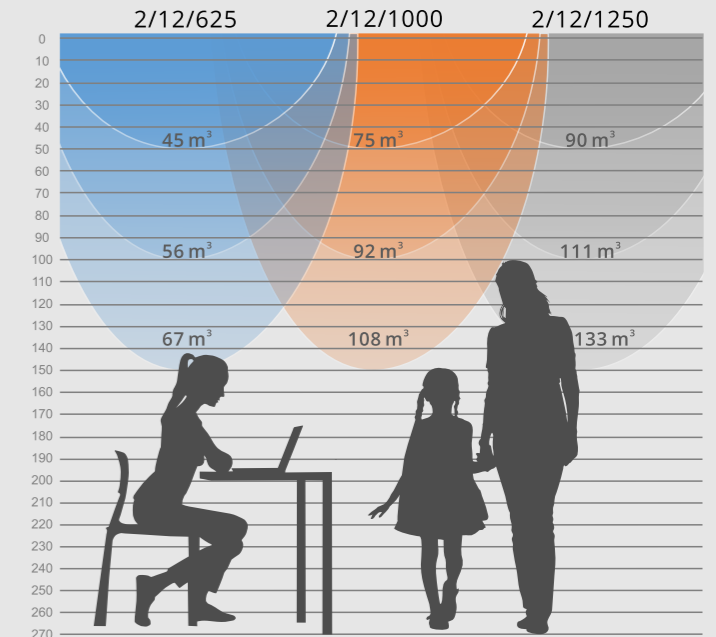

Airflow perceptible with the Line diffuser at a height of 2.70 m

PERCEPTIBLE AIRSPEED REACH LIMIT

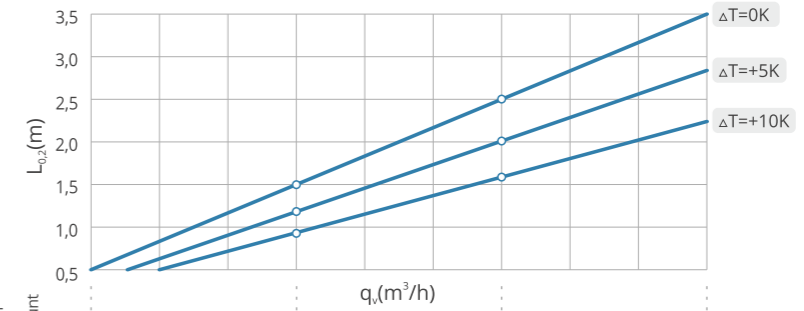

Order code:

slot length line amount slot width	45	67	88	110
LINE 625 2 12	45	67	88	110
LINE 1000 2 12	75	108	142	175
LINE 1250 2 12	90	133	177	220
LINE 625 2 18	45	75	105	135
LINE 1000 2 18	75	120	165	210
LINE 1250 2 18	90	148	206	265

Airborne noise and resistance, 1 m.

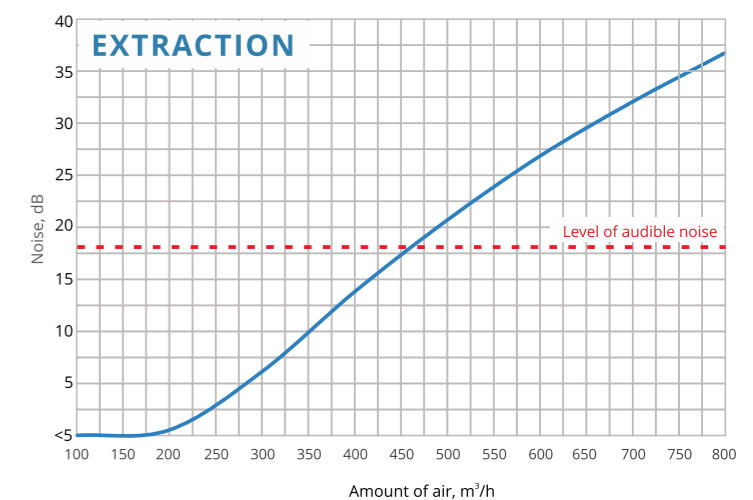
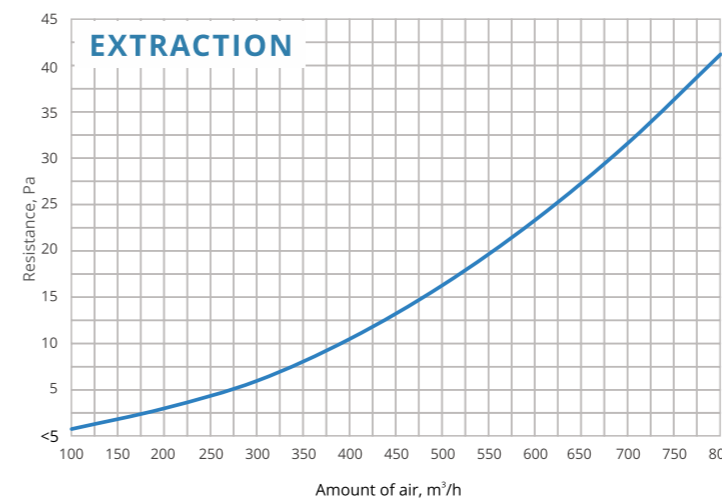
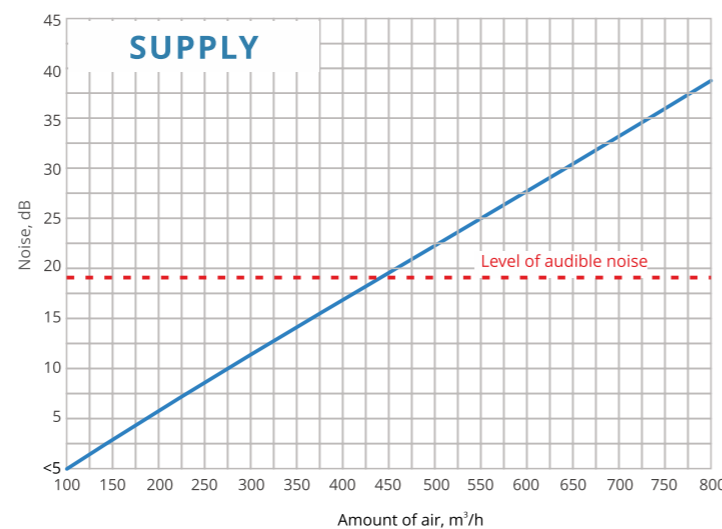
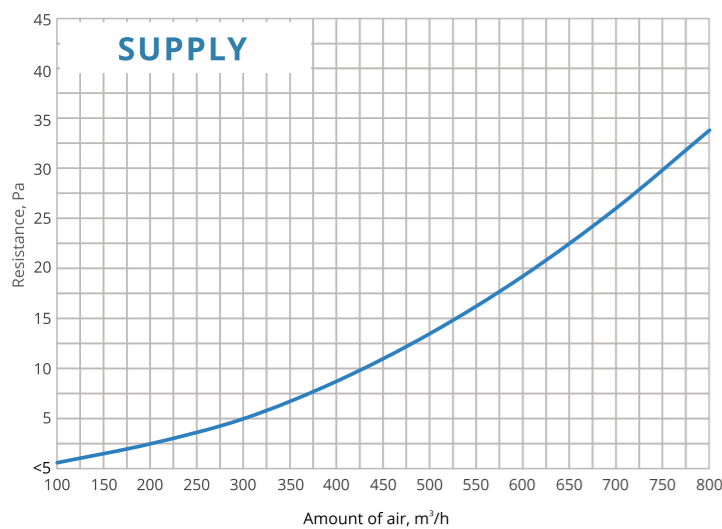

LINE 2/18

SLOT DIFFUSER

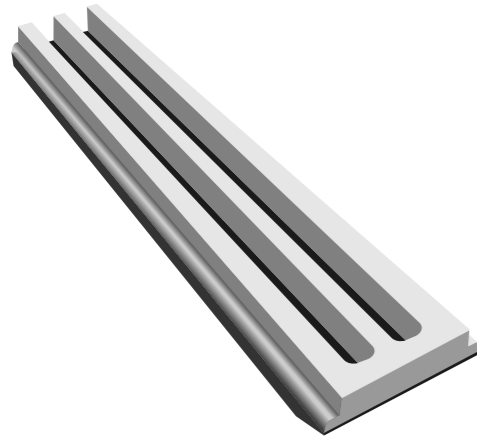

2
AMOUNT OF SLOTS

18 mm
WIDTH OF SLOT

2.735 kg
1 M. LENGTH DIFFUSER WEIGHT
WITHOUT PACKAGING (NET)

625 / 1000 / 1250
STANDARD SLOT LENGTH (MM)

Steel punched sheet. Distributes the air supply through the diffuser.

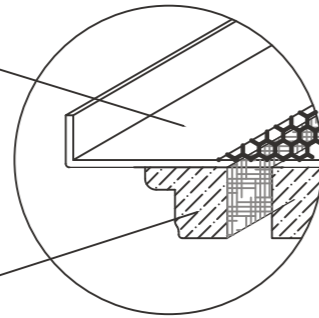

Gypsum mix segment. Sanded, puttied, painted. Suitable for all operations in combination with surface finishing

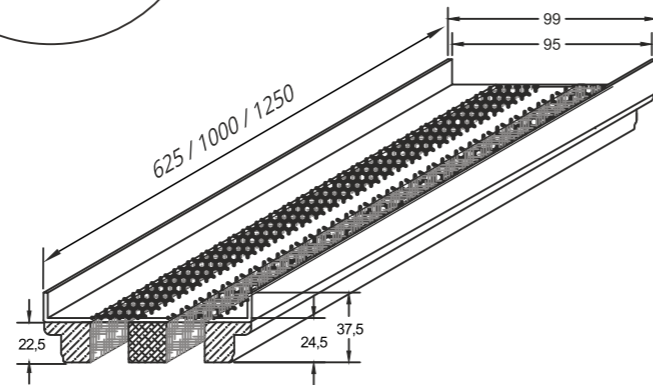
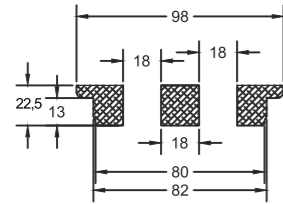

The two-slot diffuser integrates well in both walls and ceilings. It can be used in both extremely small and extremely large premises. Suitable for supplying or exhausting indoor air.

PERCEPTIBLE AIRSPEED $L_{0,2}(m)$ DISTANCE

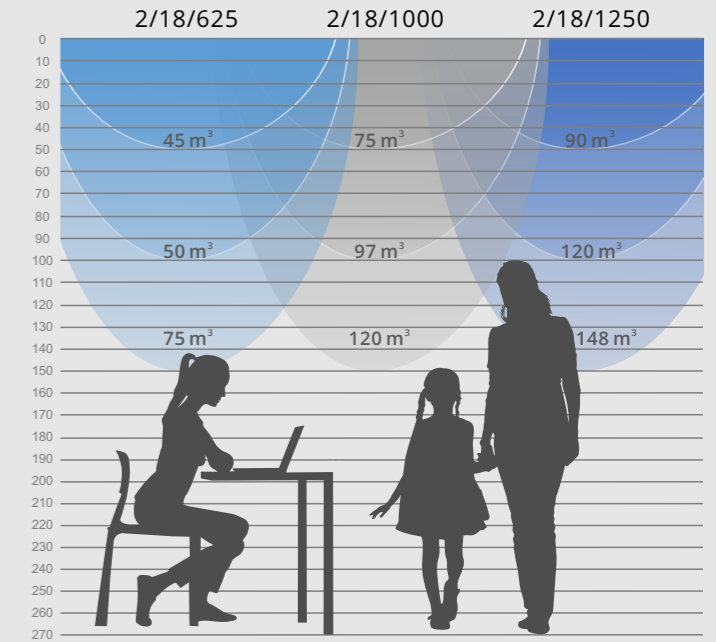

Airflow perceptible with the Line diffuser at a height of 2.70 m

PERCEPTIBLE AIRSPEED REACH LIMIT

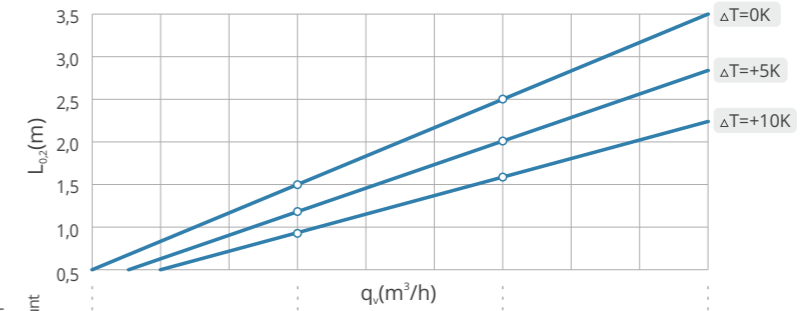

Order code:	slot length	slot amount	slot width	45	67	88	110
LINE 625 2 12	625	2	12	45	67	88	110
LINE 1000 2 12	1000	2	12	75	108	142	175
LINE 1250 2 12	1250	2	12	90	133	177	220
LINE 625 2 18	625	2	18	45	75	105	135
LINE 1000 2 18	1000	2	18	75	120	165	210
LINE 1250 2 18	1250	2	18	90	148	206	265

Airborne noise and resistance, 1 m.

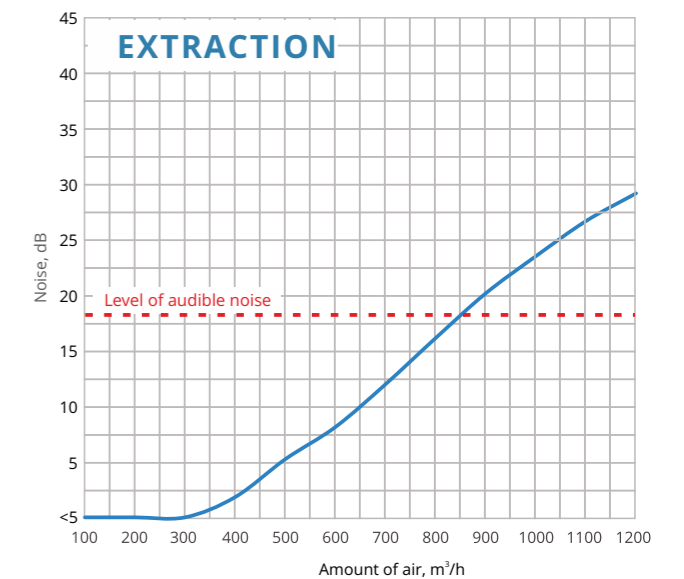
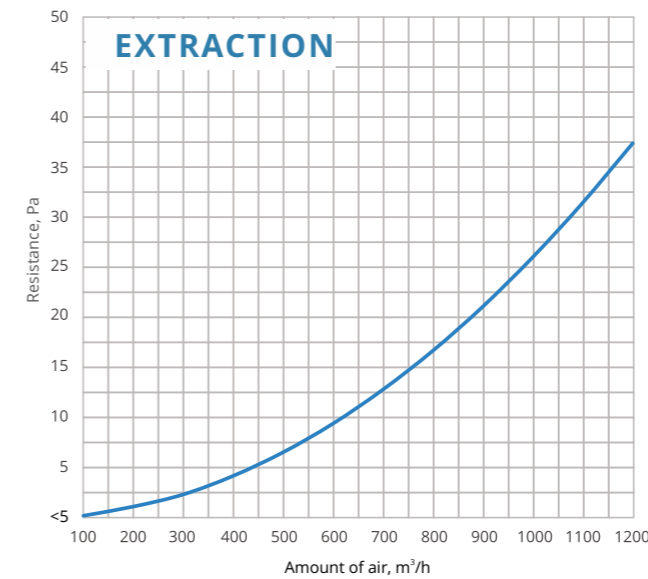
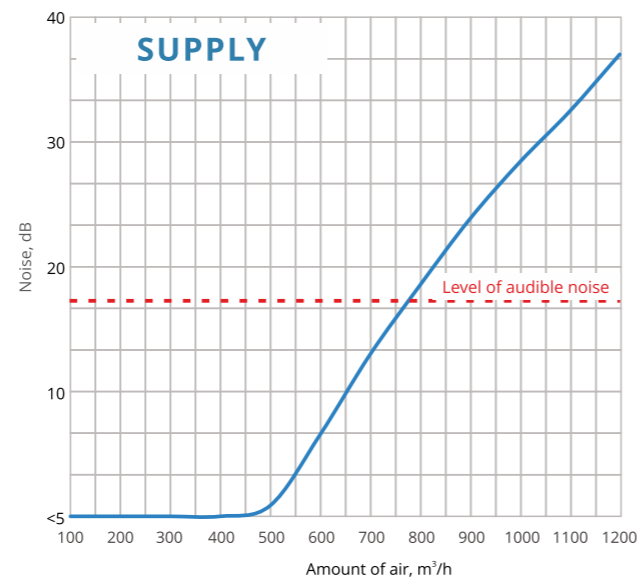
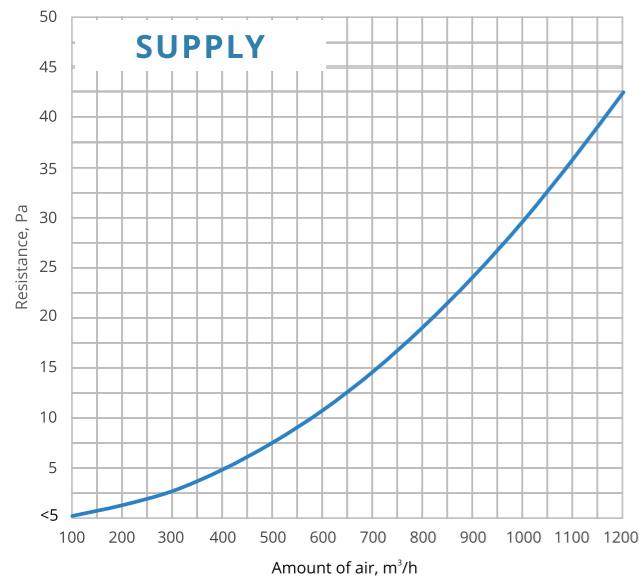

STANDARD ACUSTIC BOXES GOOD TO GO

SUITABLE FOR LINE DIFFUSERS: 1/12, 1/18, 2/12, 2,18

The junction boxes can be ordered with individual dimensions, the order sheet is at the end of the catalogue.

Order code:
GTG 75 625
Hole diameter Box length

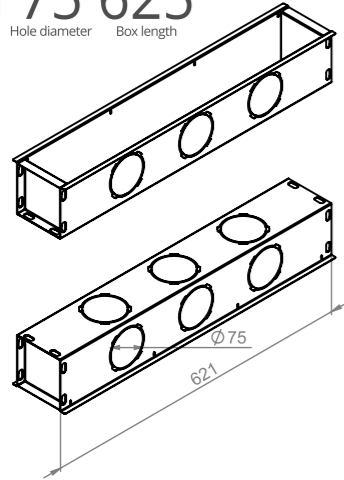

Order code:
GTG 75 1000
Hole diameter Box length

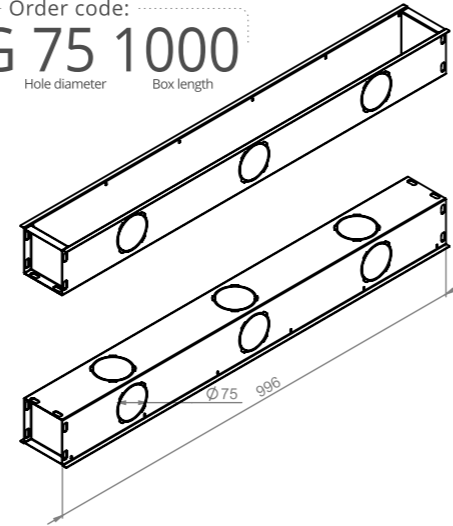

Order code:
GTG 75 1250
Hole diameter Box length

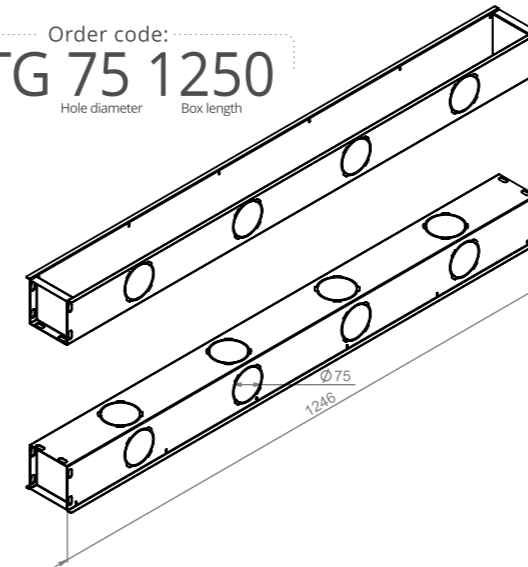

Order code:
GTG 75
Hole diameter

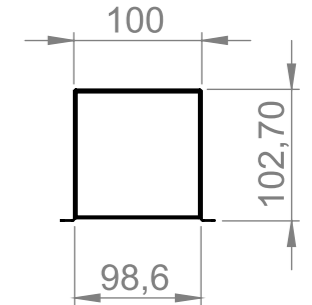

Order code:
GTG 125 625
Hole diameter Box length

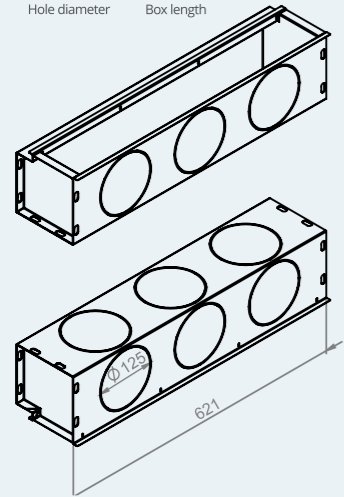

Order code:
GTG 125 1000
Hole diameter Box length

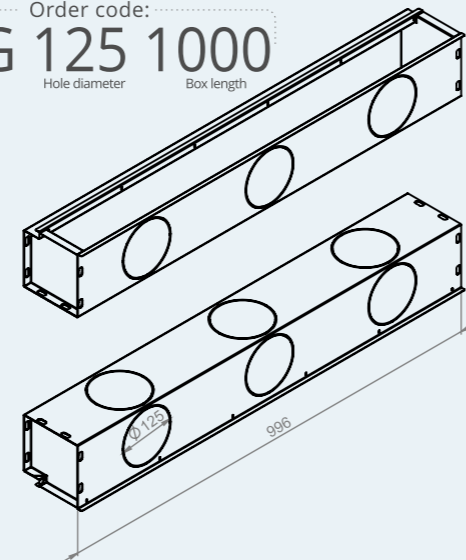

Order code:
GTG 125 1250
Hole diameter Box length

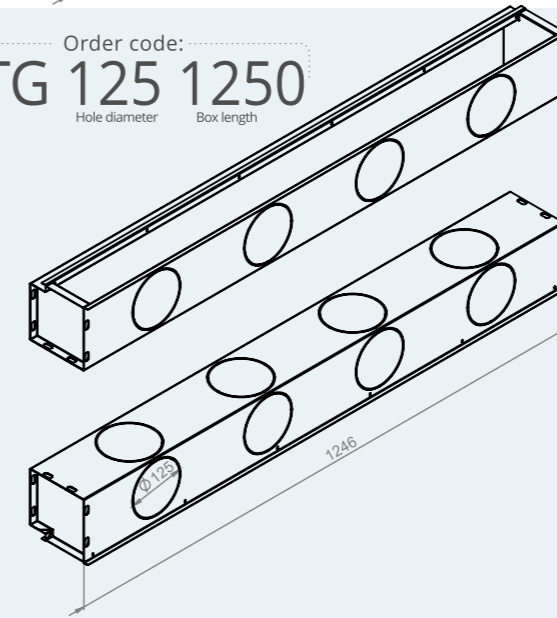

Order code:
GTG 125
Hole diameter

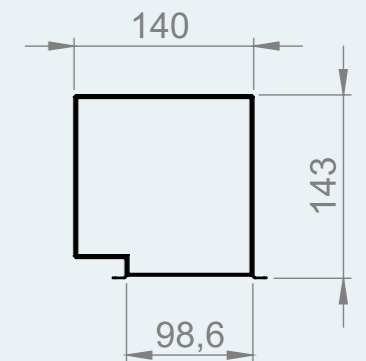

Order code:
GTG 160 625
Hole diameter Box length

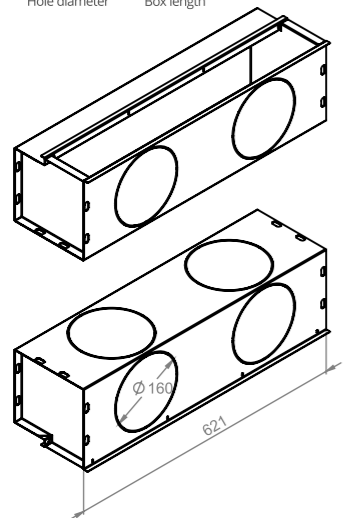

Order code:
GTG 160 1000
Hole diameter Box length

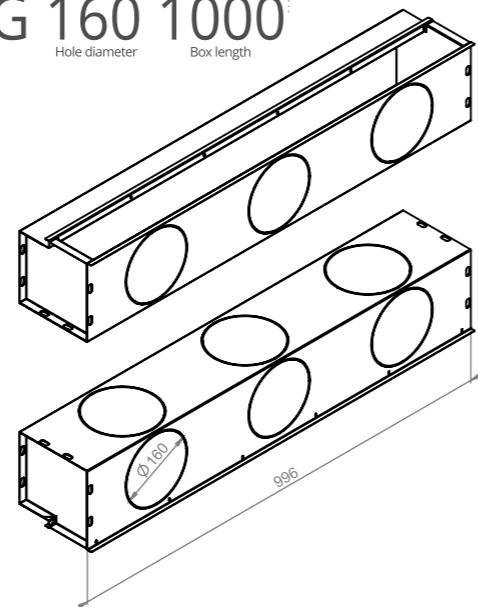

Order code:
GTG 160 1250
Hole diameter Box length

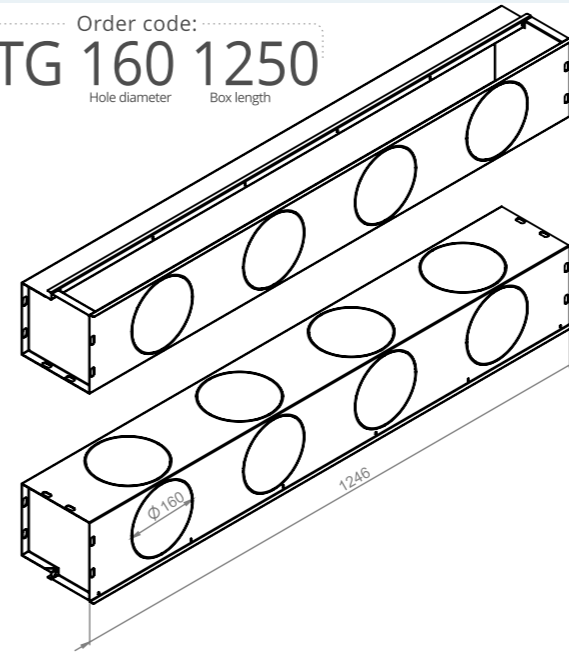

Order code:
GTG 160
Hole diameter

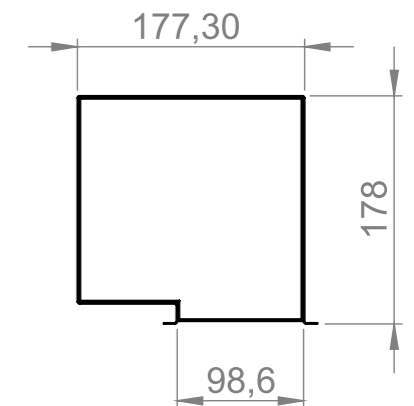

LINE 3/12

SLOT DIFFUSER

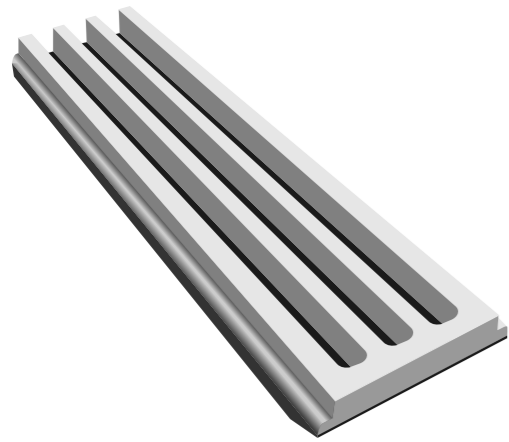

3
AMOUNT OF SLOTS

12 mm
WIDTH OF SLOT

4.085 kg
1 M. LENGTH DIFFUSER WEIGHT
WITHOUT PACKAGING (NET)

625 / 1000 / 1250
STANDARD SLOT LENGTH (MM)

Steel punched sheet. Distributes the air supply through the diffuser.

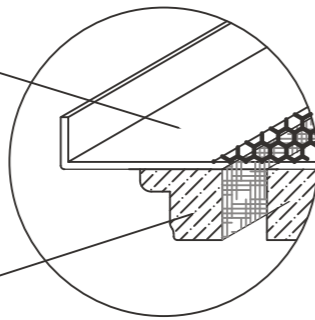

Gypsum mix segment. Sanded, puttied, painted. Suitable for all operations in combination with surface finishing

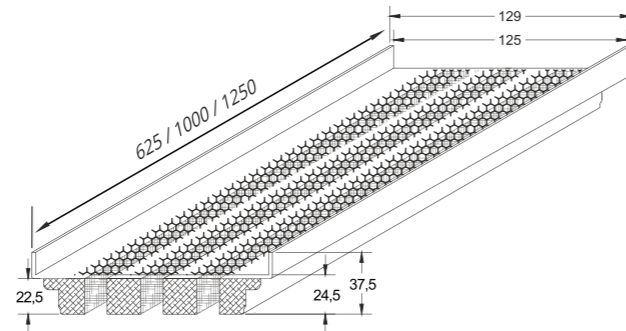
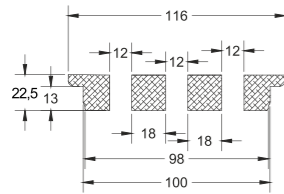

Slim version of this diffuser is characterized by lightness and elegance. It accomplishes the greatest technical tasks without obscuring the interior, causing noise or discomfort to residents

PERCEPTIBLE AIRSPEED $L_{0,2}(m)$ DISTANCE

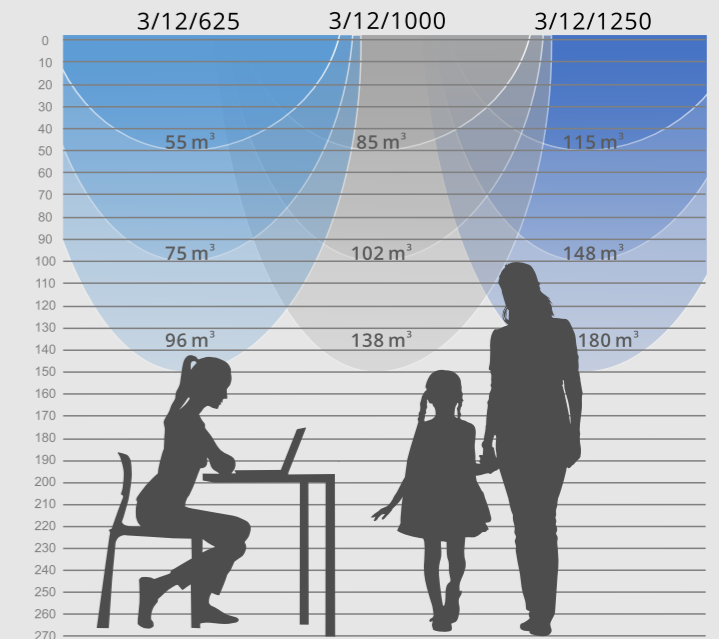

Airflow perceptible with the Line diffuser at a height of 2.70 m

PERCEPTIBLE AIRSPEED REACH LIMIT

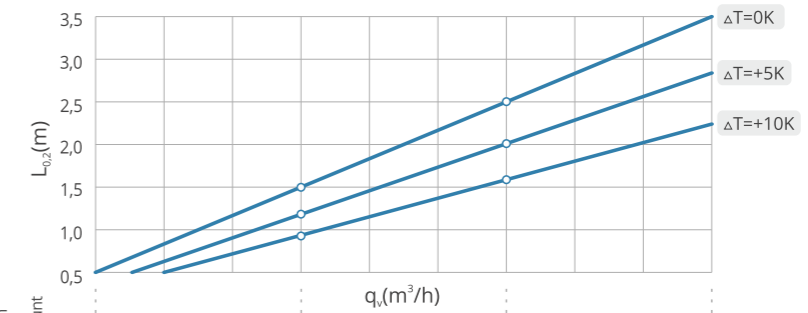

Order code:	slot length 625	slot amount 3	slot width 12	55	96	137	180
LINE 625 3 12	625	3	12	55	96	137	180
LINE 1000 3 12	1000	3	12	85	138	191	245
LINE 1250 3 12	1250	3	12	115	180	245	310
LINE 625 3 18	625	3	18	55	111	167	225
LINE 1000 3 18	1000	3	18	85	158	231	305
LINE 1250 3 18	1250	3	18	115	205	295	385

Airborne noise and resistance, 1 m.

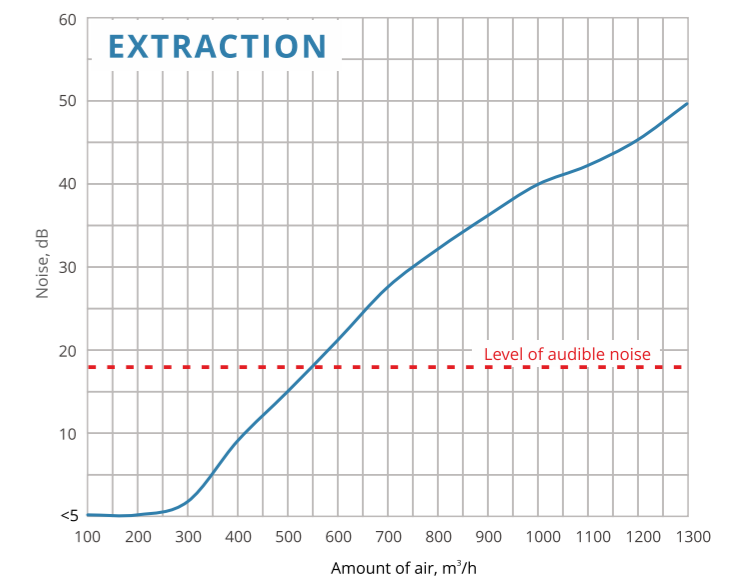
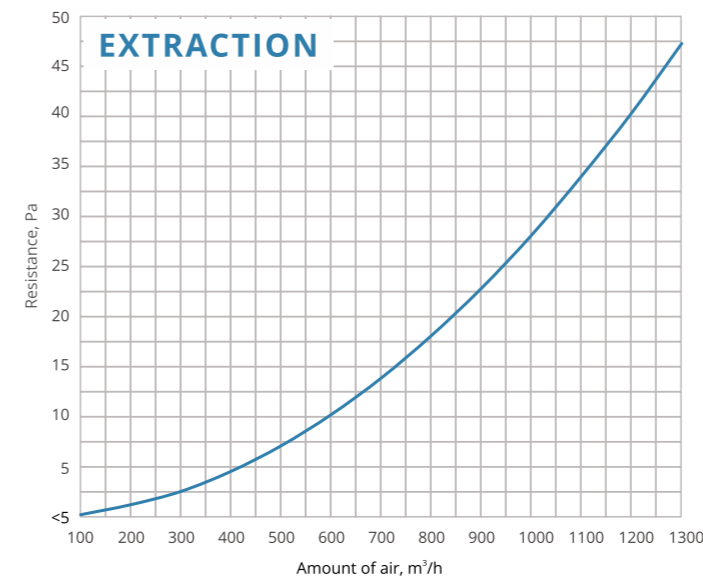
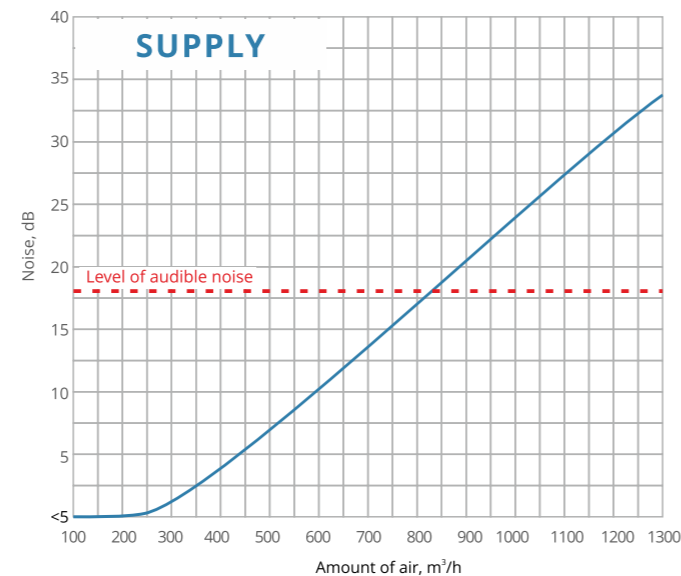
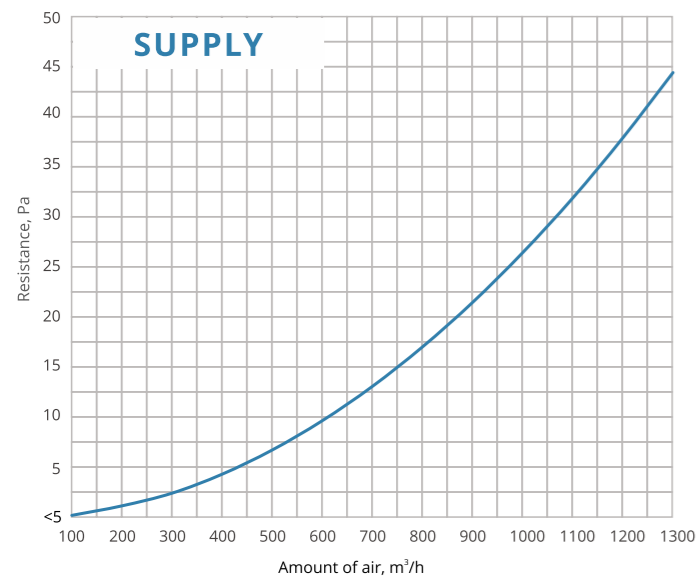

LINE 3/18

SLOT DIFFUSER

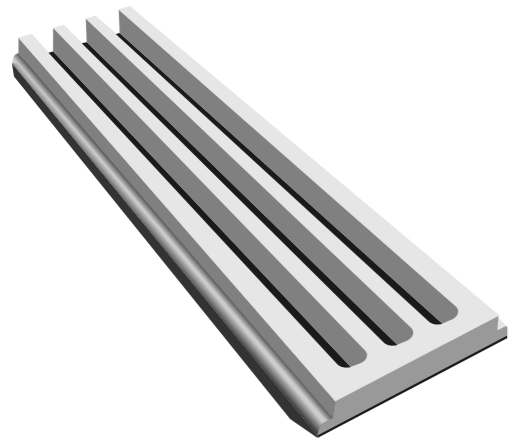

3
AMOUNT OF SLOTS

18 mm
WIDTH OF SLOT

4.085 kg
1 M. LENGTH DIFFUSER WEIGHT WITHOUT
PACKAGING (NET)

625 / 1000 / 1250
STANDARD SLOT LENGTH (MM)

Steel punched sheet. Distributes the air supply through the diffuser.

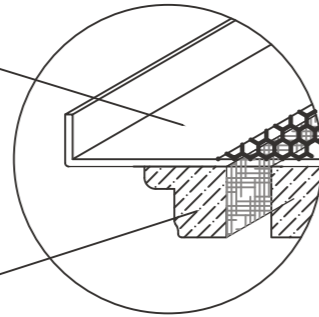

Gypsum mix segment. Sanded, puttied, painted. Suitable for all operations in combination with surface finishing

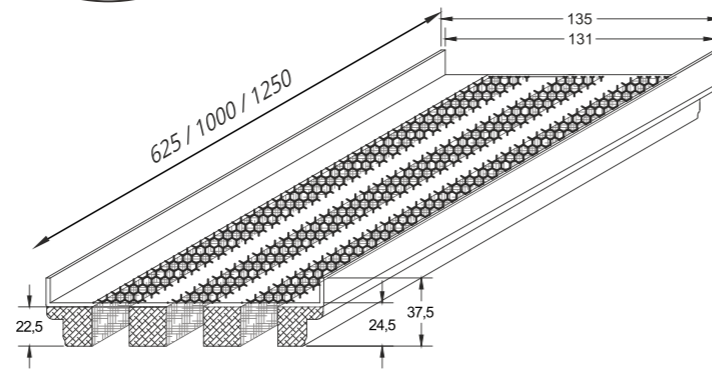
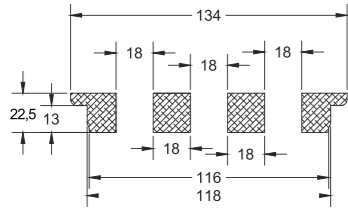

The three-slot diffuser is extremely efficient. It can let through the highest amount of air compared to other Line diffusers. It is well suited for places where changing air volumes can be a real challenge.

PERCEPTIBLE AIRSPEED $L_{0,2}(m)$ DISTANCE

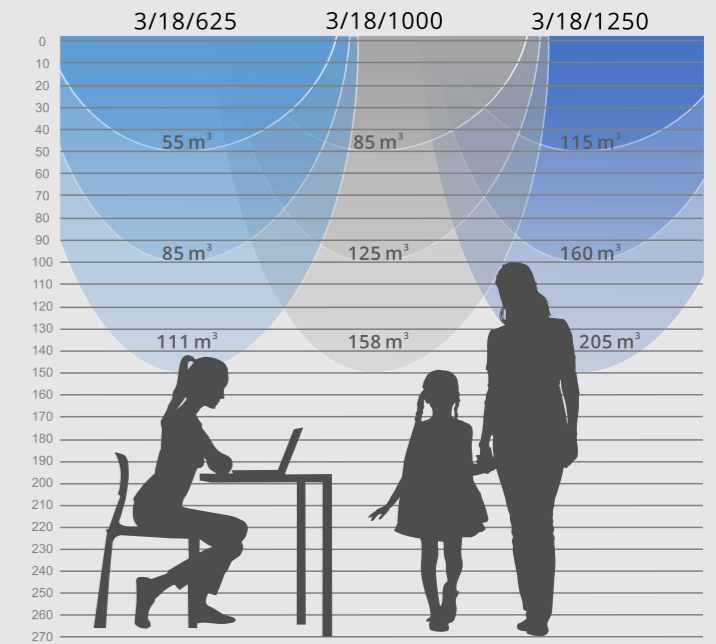

Airflow perceptible with the Line diffuser at a height of 2.70 m

PERCEPTIBLE AIRSPEED REACH LIMIT

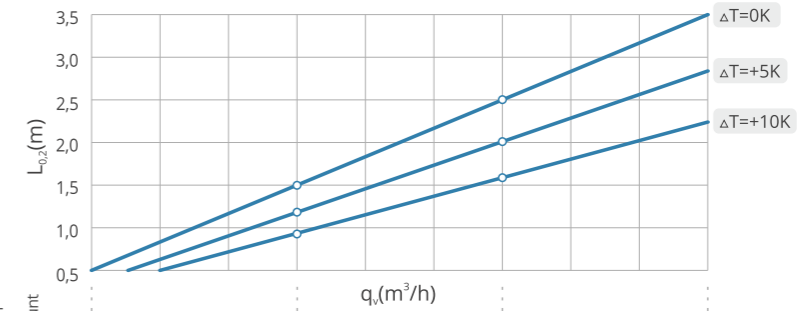

Order code:

slot length	slot amount	slot width	55	96	137	180
LINE 625	3	12	85	138	191	245
LINE 1000	3	12	115	180	245	310
LINE 625	3	18	55	111	167	225
LINE 1000	3	18	85	158	231	305
LINE 1250	3	18	115	205	295	385

Airborne noise and resistance, 1 m.

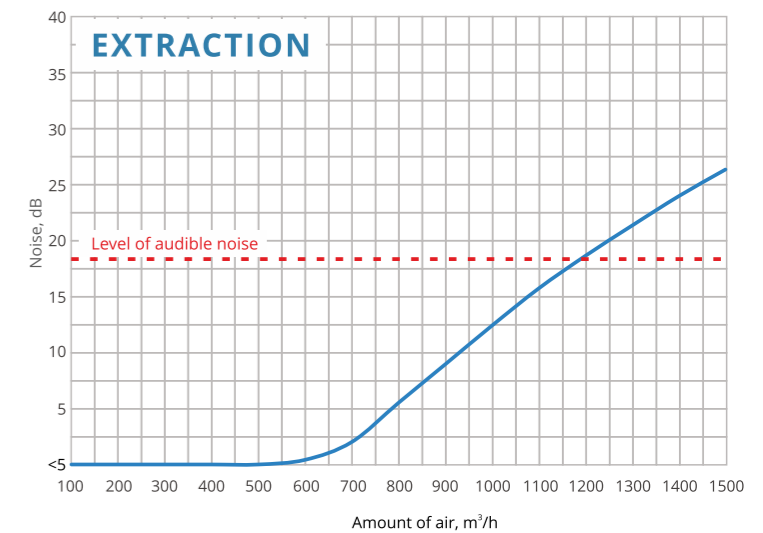
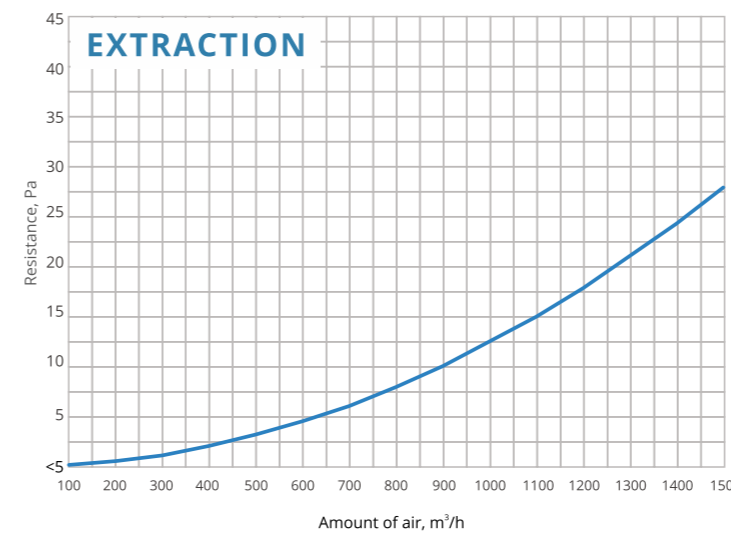
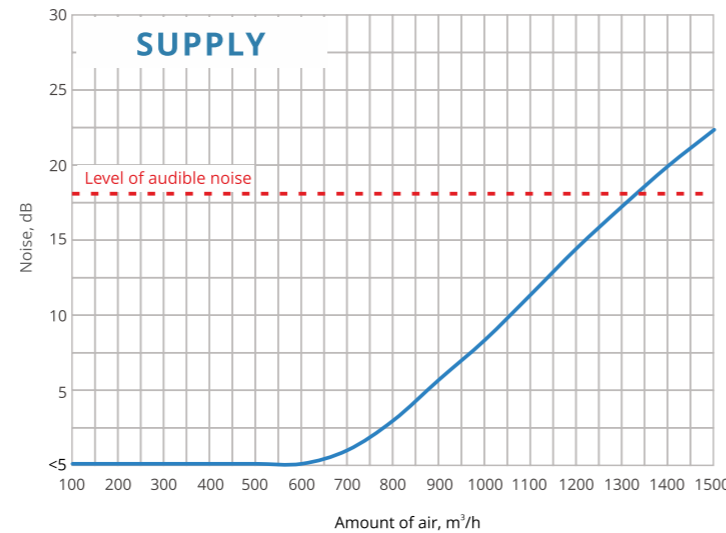
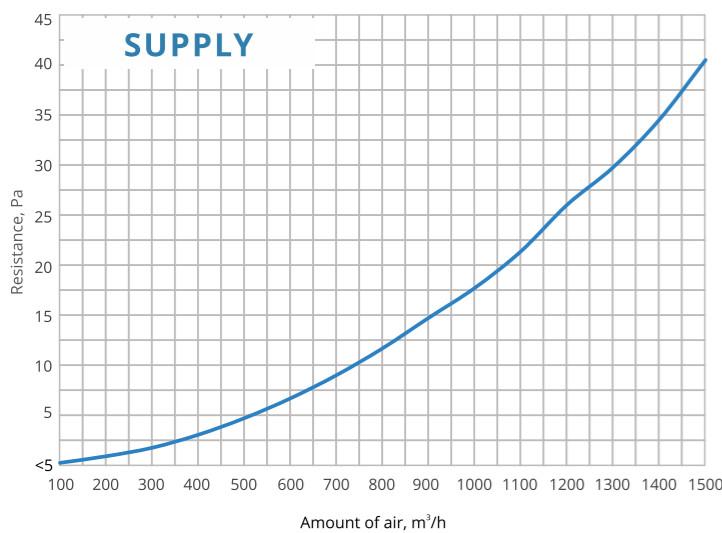

STANDARD ACUSTIC BOXES GOOD TO GO

SUITABLE FOR LINE DIFFUSERS: 3/12, 3/18

The junction boxes can be ordered with individual dimensions, the order sheet is at the end of the catalogue.

Order code:
GTG 125 625
Hole diameter Box length

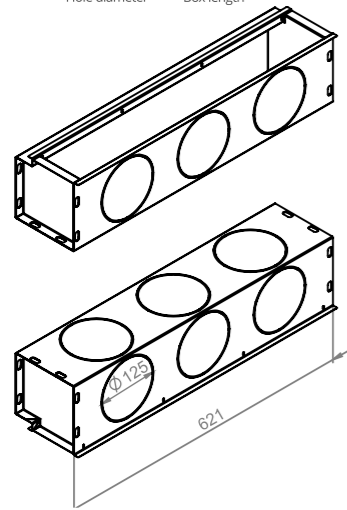

Order code:
GTG 125 1000
Hole diameter Box length

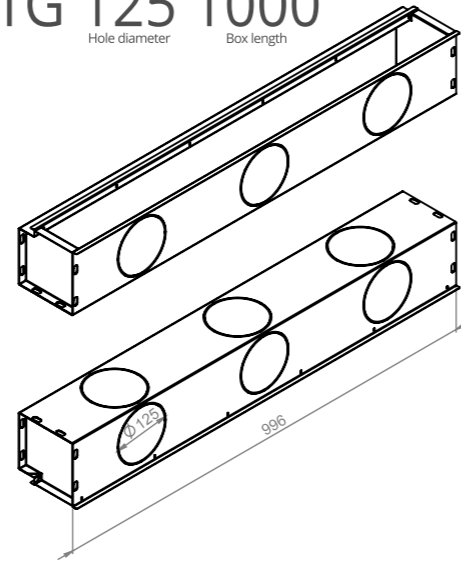

Order code:
GTG 125 1250
Hole diameter Box length

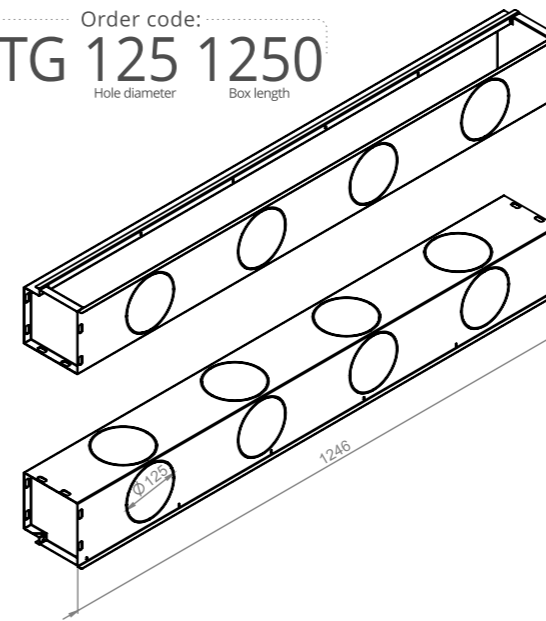

Order code:
GTG 125
Hole diameter

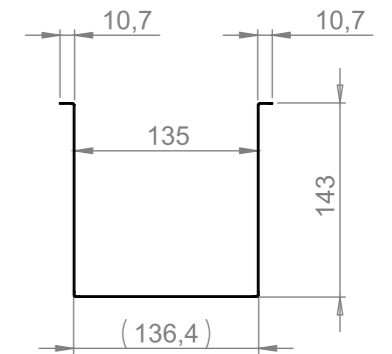

Order code:
GTG 160 625
Hole diameter Box length

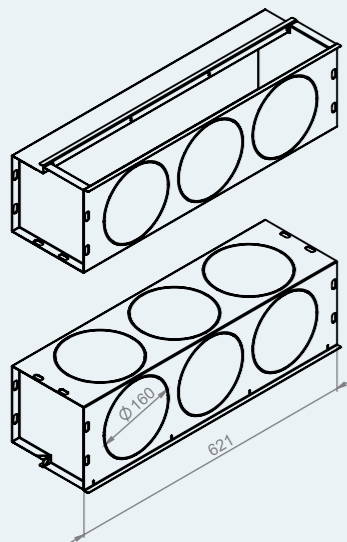

Order code:
GTG 160 1000
Hole diameter Box length

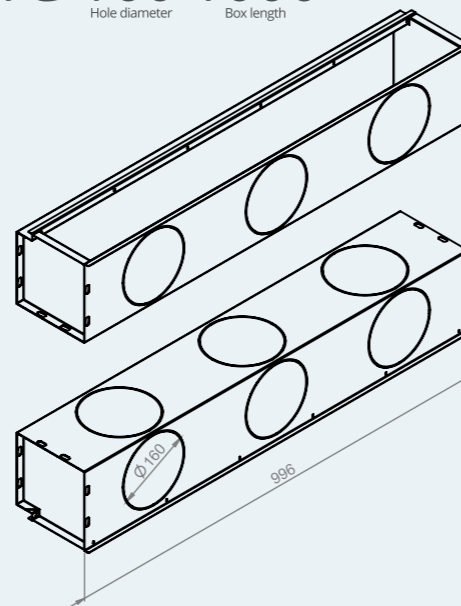

Order code:
GTG 160 1250
Hole diameter Box length

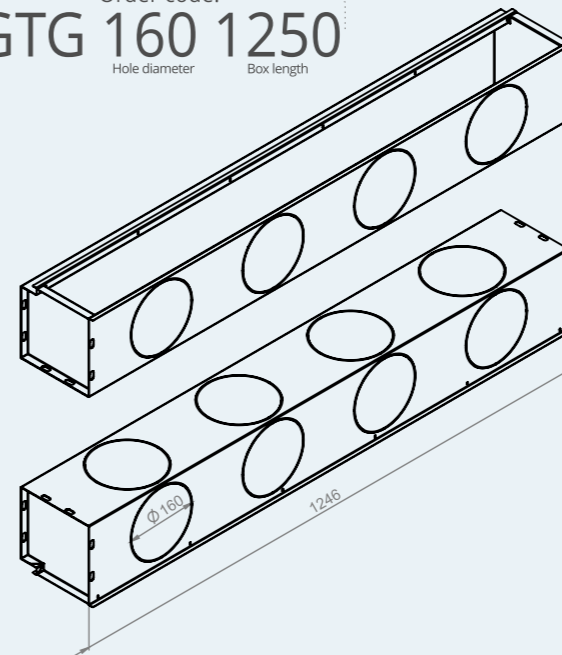

Order code:
GTG 160
Hole diameter

